

1064nm High Power Free Space Isolator



Features

Low Insertion Loss

High Isolation

High Power Handling

High Return Loss

Applications

Lasers

Test & Measurement Equipments

Amplifier

Lab Research

Performance Specifications

Parameters	Unit	Values
Center Wavelength (λ_c)	nm	1064 or Specify
Operating Wavelength Range	nm	± 10
Typ. Peak Isolation	dB	30~35
Min. Isolation at 23°C	dB	23
Typ. Insertion Loss	dB	0.3
Max. Insertion Loss	dB	0.4
Max. Optical Power (CW)	W	1, 3, 5, 10, 20 or Specify
Max. Tensile Load	N	5
Operating Temperature	°C	-5 to +50
Storage Temperature	°C	-20 to +75

Size

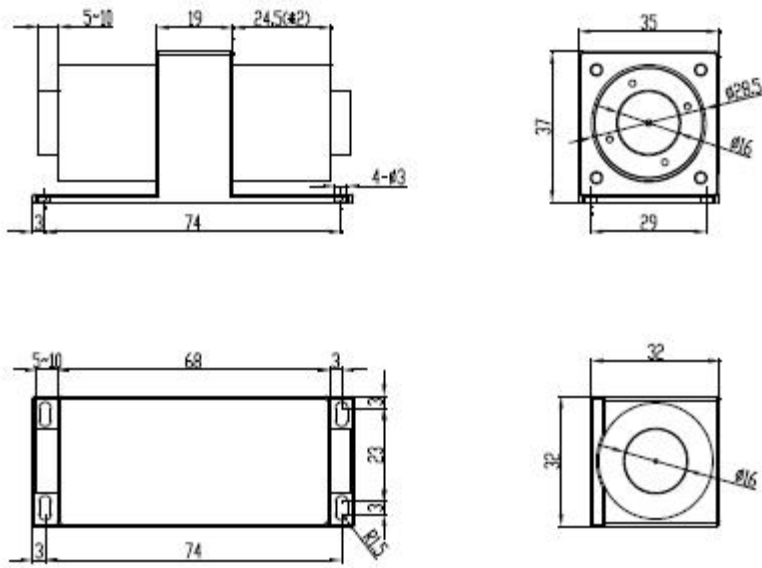

Ordering Information

HPFSI-①①-②②-③③-④

①①: Wavelength

06 - 1064nm

SS - Specify

②②: Package Type

C1 - Type C1

C2 - Type C2

③③: Handling Power

01 - 1W

03 - 3W

05 - 5W

10 - 10W

20 - 20W

④: Clear Aperture

2 - Dia. 2mm

S - Specify